

FIGURE NO.	CATALOG NO.	DIM "A" INCH. [MM]	DIM "B" INCH. [MM]	DIM "C" INCH. [MM]	RING WIRE SIZE INCH. [MM]	FASTENER TYPE	WEIGHT LBS. [KG]	STANDARD PACK
1	GM305	1.000 [25.45]	2.250 [57.26]	0.500 [12.73]	#6 (0.162) [4.12]	TORQUE SCREW	0.070 [0.03]	200
2	GM320	1.000 [25.45]	2.500 [63.63]	0.750 [19.09]	#4 (0.204) [5.19]	TORQUE SCREW	0.110 [0.05]	200
2	GM3203	1.000 [25.45]	3.250 [82.71]	0.750 [19.09]	#4 (0.204) [5.19]	TORQUE SCREW	0.120 [0.05]	200
3	GM321	1.200 [30.48]	2.500 [63.63]	0.750 [19.09]	#4 (0.204) [5.19]	TORQUE SCREW	0.070 [0.03]	200
4	GM322	1.000 [25.45]	2.500 [63.63]	0.750 [19.09]	#4 (0.204) [5.19]	PRESSED PIN	0.110 [0.05]	200
4	GM3223	1.000 [25.45]	3.250 [82.71]	0.750 [19.09]	#4 (0.204) [5.19]	PRESSED PIN	0.120 [0.05]	200

ITEM	DESCRIPTION	MATERIAL
1	BODY	EXTRUDED ALUMINIUM ALLOY
2	RING	ALUMOWELD
3	BOLT	ALUMINIUM
4	PIN	SPRING STEEL

B

B

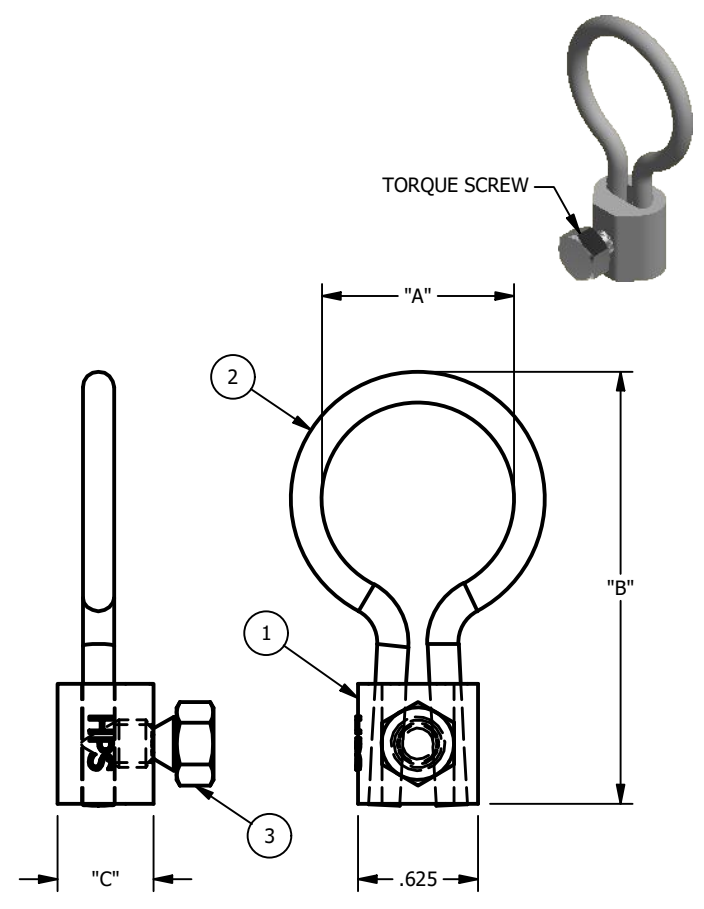

FIG 1

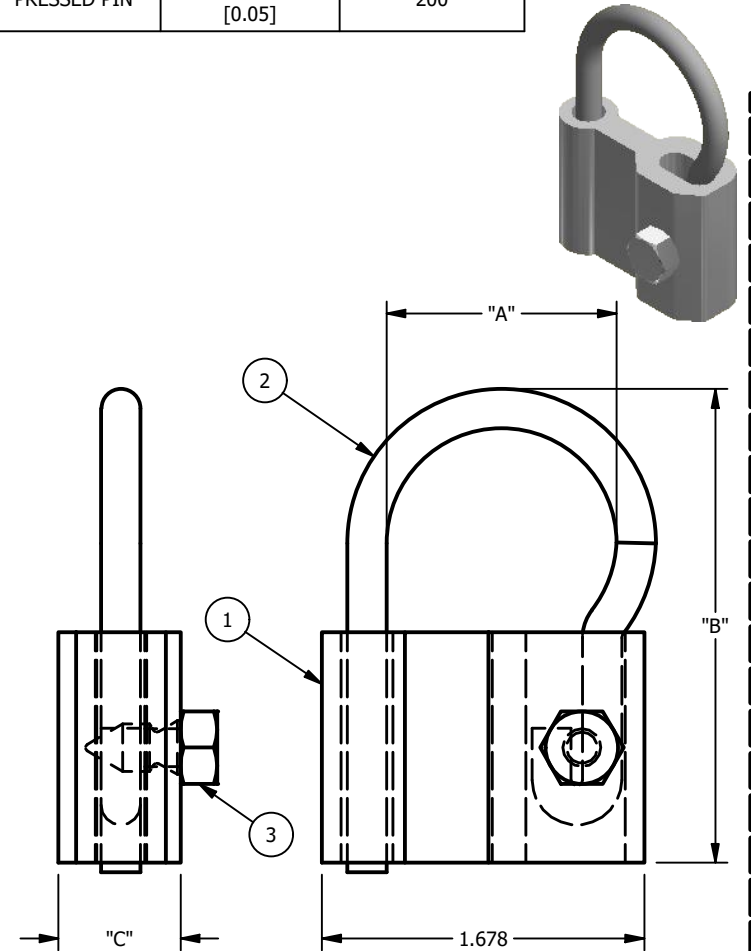

FIG 2

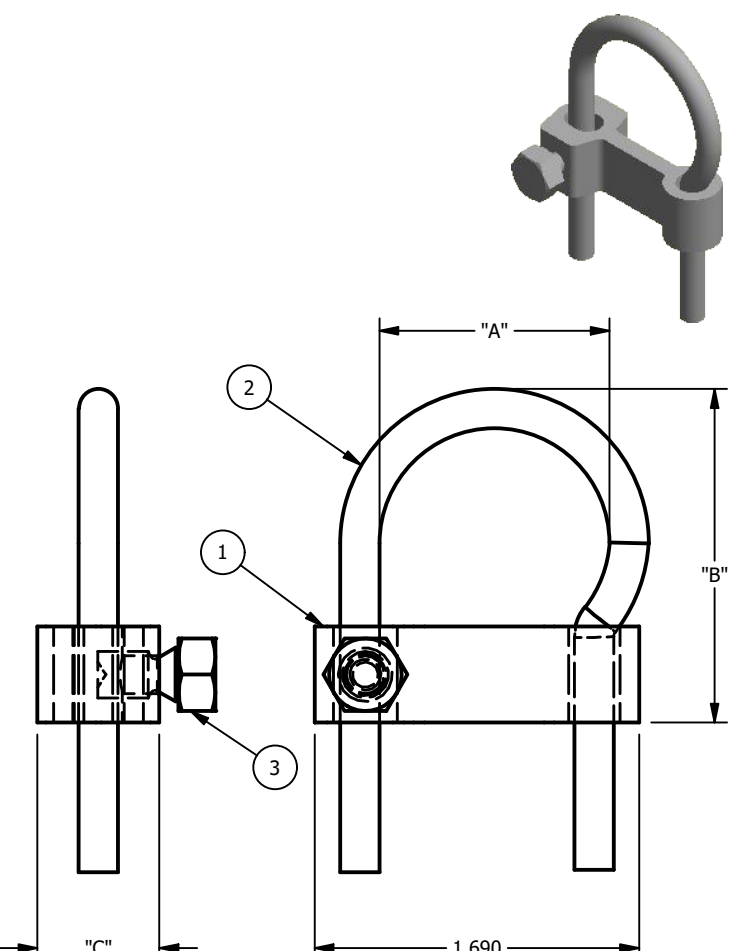

FIG 3

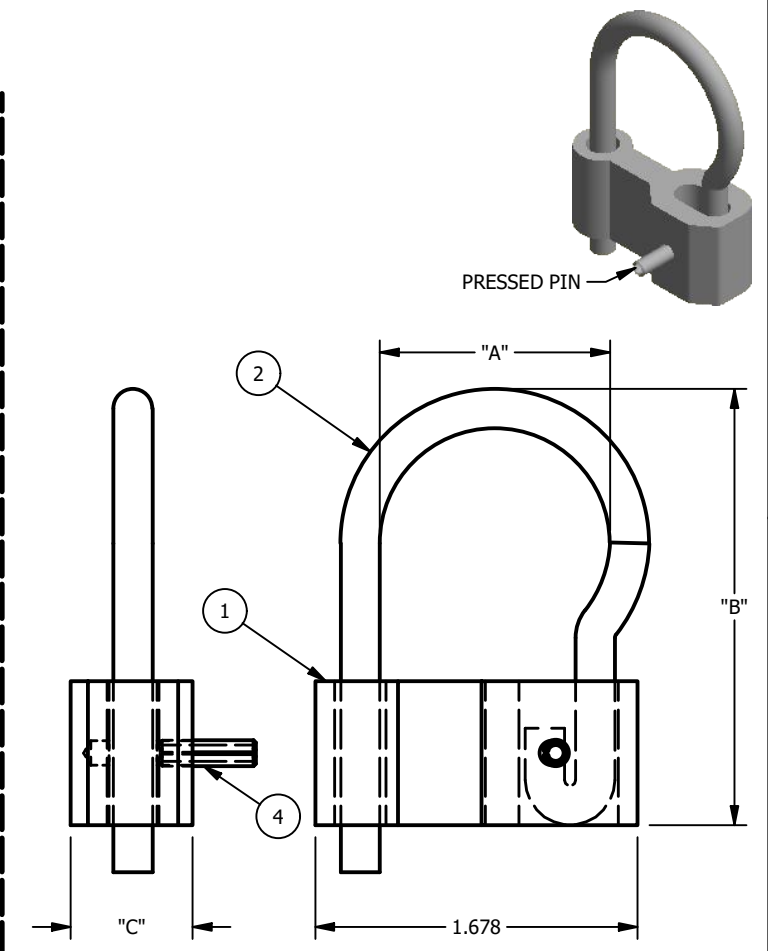

FIG 4

A

A

- NOTES:
- ALL DIMENSIONS FOR REFERENCE ONLY. DISTANCE IN. [MM], FORCE LBS. [kN], TORQUE IN. LBS. [N.m] & WEIGHT LBS. [KG]
  - RATINGS:
    - A. NA
  - SUFFIXES & VARIANT CONFIGURATION:
    - A. NA

21115014370	11/15/21	SAV	AC	SD
EC #	DATE	CHANGED BY	CHECKED BY	APPROVED BY
DESCRIPTION: REMOVED CATALOG GM306 & GM307 FROM TABLE DRAWING VIEW ADJUSTED AND DIMENSIONS UPDATED				WEIGHT, LBS SEE TABLE
ADDITIONAL COMMENTS: --				THIRD ANGLE PROJECTION

CONFIDENTIAL:  
THIS DRAWING AND ITS CONTENTS ARE CONFIDENTIAL AND THE EXCLUSIVE PROPERTY OF HUBBELL POWER SYSTEMS. NO PUBLICATION, DISTRIBUTION OR COPIES MAY BE MADE WITHOUT THE WRITTEN CONSENT OF HUBBELL POWER SYSTEMS. HUBBELL POWER SYSTEMS UNPUBLISHED ALL RIGHTS RESERVED UNDER THE COPYRIGHT LAWS

**HUBBELL** POWER SYSTEMS, Inc.  
POWER SYSTEMS, INC.

TITLE  
**TAMPERPROOF EQUIPMENT LOCKS**

CATALOG NUMBER: SEE TABLE

SIZE <b>B</b>	DWG NO. <b>CC-26887</b>	PART / ASSY NO. <b>SEE TABLE</b>	REV <b>03</b>
------------------	----------------------------	-------------------------------------	------------------

SCALE: 1 : 1 DRN BY **MK** DATE **01/12/20** SHEET 1 OF 1